

**Model** : ATZ LRM3X56

**Description** : 3.5U Triple 5.6" LCD Rackmount Industrial Monitor  
- Optimize rack space. Maximize rack monitoring -

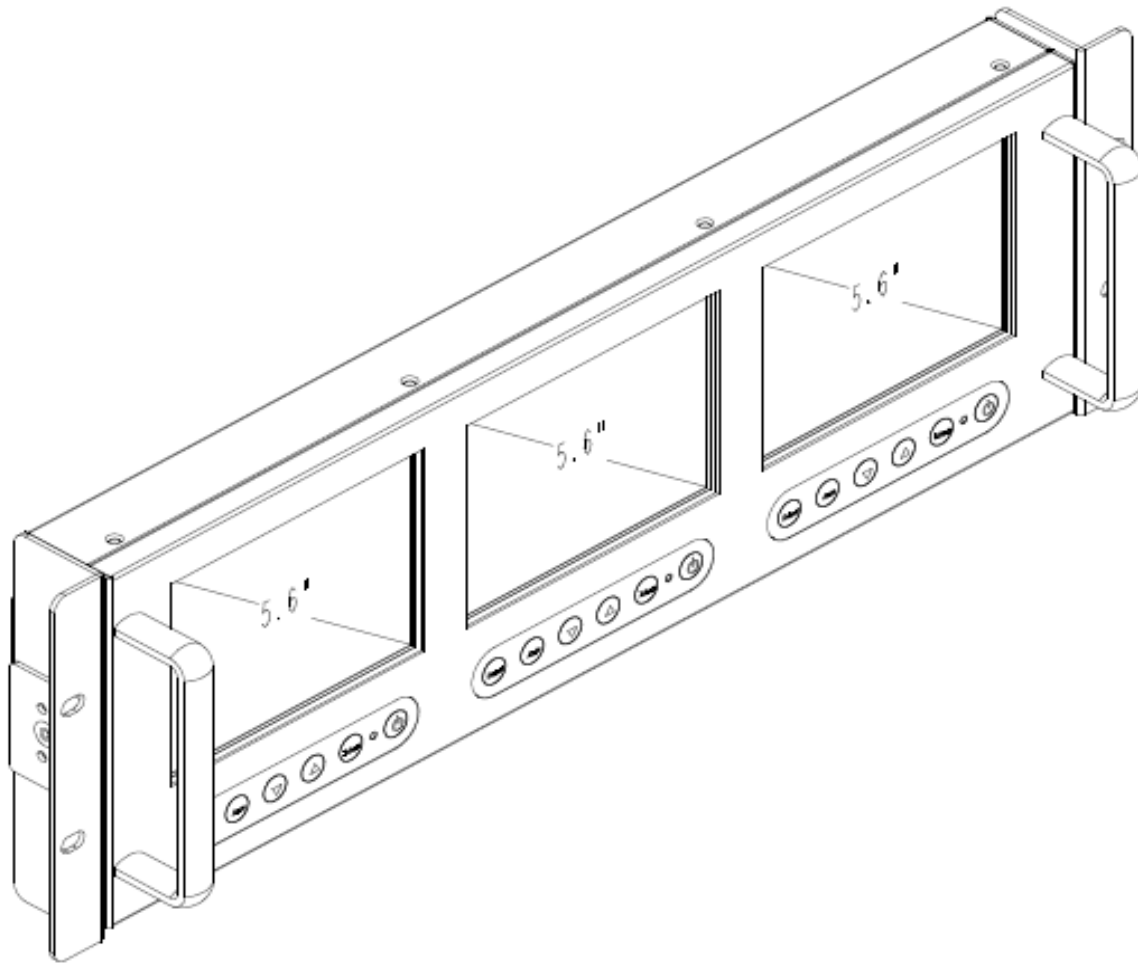

### Features:

- Compact 19 inch rack mountable with 3.5U height
- Triple 5.6 inch LCD panel, support 640 x 480 resolution
- VGA, Composite Video Input
- 90° tilt adjustment while mounted in rack: 45°~ -45° ( V )

pg. 1

**Notes:** - All brand names and trademarks are properties of their respective holders and are referred to here for descriptive purpose only. Photo attached is for reference only, it may be slightly varied in items of colour, shape from the actual item delivered from time to time.

**Model** : ATZ LRM3X56

**Description** : 3.5U Triple 5.6" LCD Rackmount Industrial Monitor  
- Optimize rack space. Maximize rack monitoring -

- Heavy duty steel chassis with hardness glass protect screen
- Front OSD control buttons to optimized display

**Option:**

- DC 9~36 V power input
- AR Hardness glass
- Touch screen

**Specifications:**

User Controls Interface:	
Power ON / OFF via Front Button	
Power Mode Status LED indicator	
OSD ( On Screen Display ) Buttons	
LCD Characteristics :	
Screen Size	5.6 inch
Backlight Type	LED
Resolution	640x480
Contrast Ratio	500:1
Brightness ( cd/m2 )	200
View Angles ( H/V )	140/120
Pixel Size ( HxV ) mm	0.0588x0.1764
Max. Color	262K
MTBF ( Hrs. )	50,000
Mechanical and Environment:	
Height	3.5U
IP Protect	N/A
Mounting	Rack Mount
Construction	Metal Housing
Operating Temperature	0 - 50 deg. C
Operating Humidity	5% - 95% ( non -condensing )
Anti-Vibration	5 - 500 Hz / 1 Grms PTP
Anti-Shock	15G / Peak ( 11 ms )

pg. 2

**Notes:** - All brand names and trademarks are properties of their respective holders and are referred to here for descriptive purpose only. Photo attached is for reference only, it may be slightly varied in items of colour, shape from the actual item delivered from time to time.

**Model** : ATZ LRM3X56

**Description** : 3.5U Triple 5.6" LCD Rackmount Industrial Monitor  
- Optimize rack space. Maximize rack monitoring -

Physical Dimension (WxHxD)	482 x 152 x 63 (mm)
Packing Dimension (WxHxD)	600 x 190 x 290 (mm)
Net Weight / Gross Weight	(KGs)
Certification and Approvals	CE / FCC / RoHs
<b>Input Signals:</b>	
VGA	D-SUB 15Pin Connector (Female)
Composite Video	RCA plug
Audio	3.5" Jack
Power Input	External power adapter
Touch-USB ( option )	USB A Type connector
Touch-RS232 ( option )	D-SUB 9P connector ( Female )
<b>Power Specifications :</b>	
AC Power Input	100-240VAC / DC 12V external AC adapter
Wide Range DC Power Input (option)	Screw Type Terminal Block with internal wide Range DC 9-36V power module

### Product Diagram:

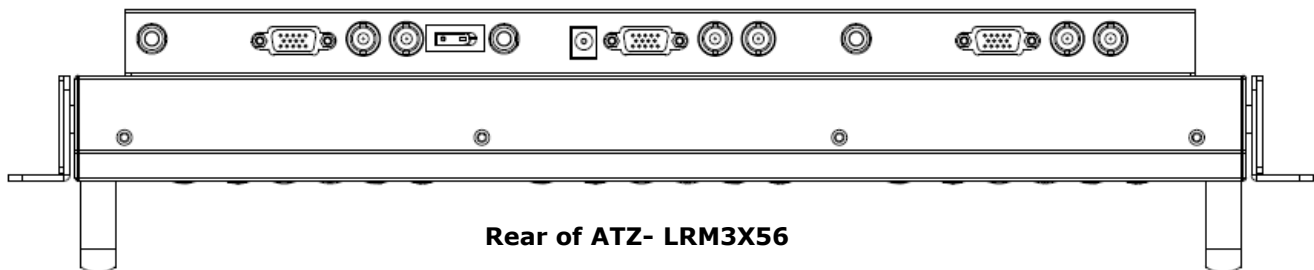

**Rear of ATZ- LRM3X56**

**Model** : ATZ LRM3X56

**Description** : 3.5U Triple 5.6" LCD Rackmount Industrial Monitor  
- Optimize rack space. Maximize rack monitoring -

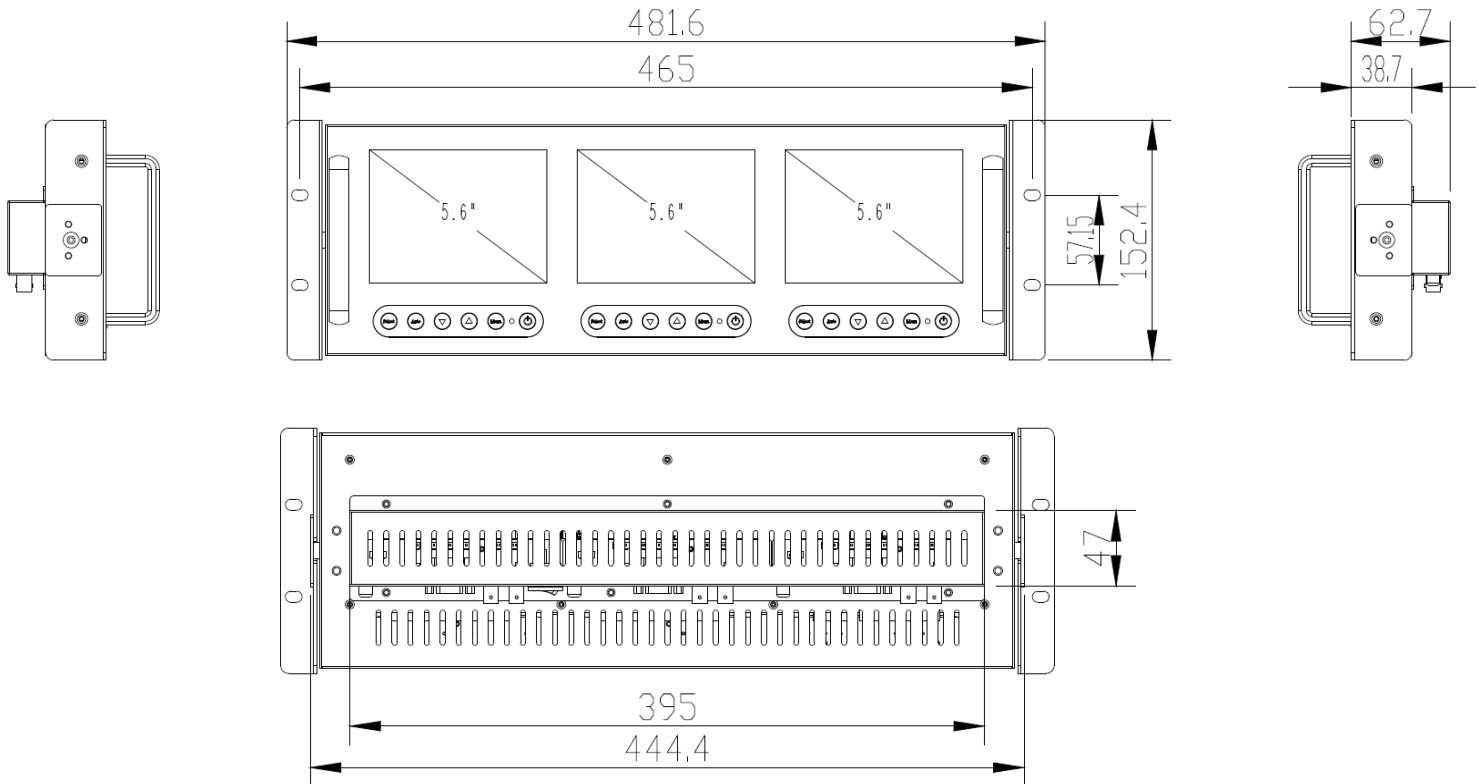

### Warranty: 3 Years

Warranty is effective from the date of original delivery.

This warranty shall be void if a serial number has been removed from the product.